



ARTICULATING & TELESCOPIC BOOMS

CUSTOMERS FIRST. ALWAYS.

PARTNERING FOR SUCCESS

Our dedication to lifting you higher extends well beyond the physical reach of our products. We thrive on building satisfying customer relationships founded on the idea of partnership. Because you, our customer, are at the centre of everything we do.

Since 1966, we've been developing products to solve your worksite challenges – and that process never ends. Our team of product managers and engineers uses your input to design new products, featuring the latest technology to meet your changing needs. Then we manufacture those products to stringent standards that help increase quality, lower costs and give you exceptional value for years to come.

PROVIDING SUPERIOR VALUE

Our commitment doesn't end with the sale. Our dedicated service teams are available to provide support when you need it most. Our extensive parts network ships most parts within 24 hours, too. Simply put, we're always working to help maximise your "up time" so you can be more successful.

Genie is driven by one goal: doing the right thing, at the right time for our customers. That's not just what we do; it's who we are. So tell us what you need. We're listening.



Genie
A TEREX BRAND

SETTING THE STANDARD

Genie manufactures some of the most advanced, highest-valued lift equipment in the industry. Genie distinctive blue lifts set the standard for performance and durability – not to mention support from people who understand your business.



REACH AND PERFORMANCE FOR EVERY JOB

Get the reach and reliable performance you need to get the job done from the ever-growing line of Genie® articulating and telescopic booms. Electric or engine-powered – for indoor, outdoor or rough terrain applications – there's a Genie® lift for every job.

Genie® articulating Z™-booms provide the ultimate in versatility with up, out and over positioning capabilities for hard-to-access work areas. Genie® telescopic S™-booms are engineered to enhance working efficiency and offer greater horizontal outreach than any other type of aerial platform. And all of the booms can be customised with a variety of options and packages to fit your individual job site needs.

Genie revolutionized the industry with the first articulating boom and remains a world leader in lifts.

NARROW ACCESS SOLUTIONS

Drive through standard doorways, work close to buildings or around obstacles, and access overhead work from aisles and other congested areas. It's all possible with Genie® narrow electric lifts. From tight turning to a rotating platform, they're designed with features that make it easy to manoeuvre precisely where you need to work. Working heights range from 11.14 m (36 ft) to 14.32 m (46 ft 5 in).

TIGHT ACCESS MANOEUVREABILITY

The electric boom line includes a variety of narrow models ideal for the tightest, most confined work areas. These compact designs feature a tight turning radius with zero tailswing on most models for easy manoeuvring through narrow aisles and standard doors.



EXCEPTIONAL CONTROL

Proportional lift and drive controls allow precise positioning of the boom and smooth drive performance. For added flexibility, the energy-saving new Z™-40/23N RJ control system allows efficient operation of multiple functions at the same time – which allows you to get where you need to go faster.

The Genie® Z™-40/23N RJ models are the first in the industry to feature the efficient new AC drive system.

PRECISE POSITIONING

The self-leveling platform rotates 90° to either side, while the jib boom moves 130° to 139° vertically, depending on the model. The 1.22 m (4 ft) jib moves horizontally 180° on rotating jib (RJ) models for extra working range. Proportional controls allow you to control the speed of each function and make smooth, precise adjustments in tight areas.



RELIABLE ELECTRIC DRIVE SYSTEMS

Several models feature a 48 V DC electric drive system, which can be freely used in areas where quiet, emission-free operation is important. The Z™-40/23N RJ model is the first in the industry to feature Genie's new AC drive system, which combines DC batteries with 3-phase AC drive motors for quiet, more energy efficient operation and longer battery life. This advanced system yields better drive speed and gradeability, and the drive wheels work independently for excellent traction control.



NARROW MODELS AVAILABLE

Z™-30/20N RJ

Z™-34/22N

Z™-40/23N RJ

DC POWER OPTIONS

FOR DEMANDING JOBS

Genie's efficient DC machines offer quiet, emission-free operation in the most sensitive work environments. These units handle challenging jobs all day long, giving you the power to get where you need to go quickly and easily with excellent manoeuvrability and zero tailswing. Non-marking foam-filled tyres also make these models great for industrial applications. Working heights range from 12.52 m (40 ft 6 in) to 15.94 m (51 ft 9 in).

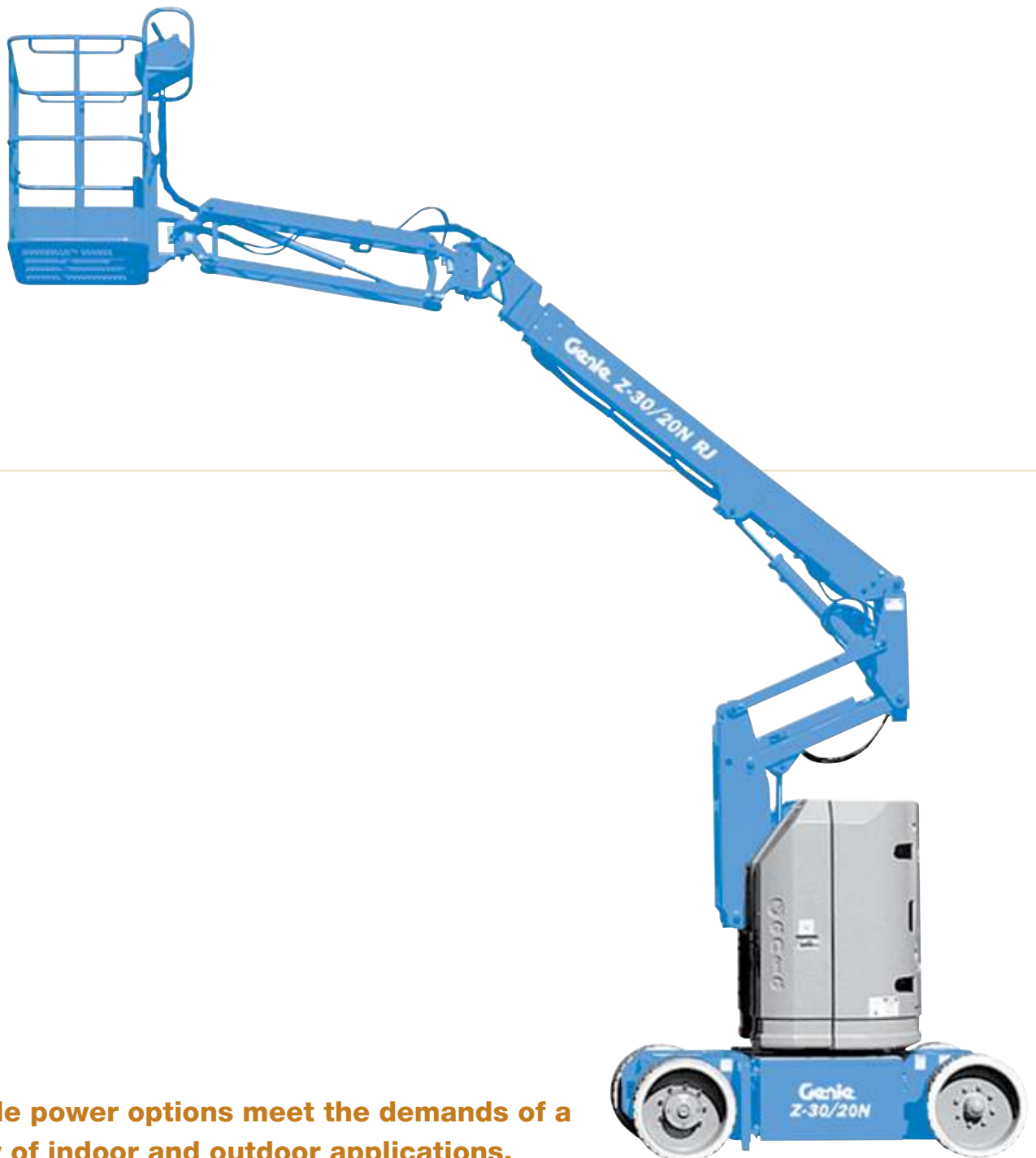

Multiple power options meet the demands of a variety of indoor and outdoor applications.

PRECISE POSITIONING AND CONTROL

The self-leveling platform rotates 80° to either side and the jib moves 135° to 139° vertically, depending on the model. Proportional lift and drive controls allow you to determine the speed of each function and make smooth, precise movements to position yourself exactly where you need to work.

ACCESS AND MANOEUVREABILITY

These models offer ideal up and over reach in confined work spaces. Zero tailswing means there's no need to reposition the lift when rotating the turntable in crowded areas. And the compact size suits applications where a lower machine weight is needed.

ON-BOARD BATTERY CHARGING

The direct electric, 48V drive system provides outstanding battery life between charges. For overnight recharging, the on-board 30 amp universal smart charger automatically adjusts to the input AC voltage and frequency and shuts down when the battery pack is fully charged.



DC MODEL AVAILABLE

Z™-45/25J DC

EXCELLENT POSITIONING

MEETS SUPERIOR HANDLING

Genie® engine-powered articulating Z™-booms provide lifting versatility with a stunning combination of up, out and over positioning capabilities and extensive outreach. They also offer high ground clearance, four-wheel drive and rough terrain features for easy travel over irregular ground. Ideal for outdoor construction and industrial applications, these units have working heights between 12.52 m (40 ft 6 in) and 20.39 m (66 ft 4 in) and reach out a maximum of 6.78 m (22 ft 3 in) to 11.05 m (36 ft 3 in).



JOB SITE ACCESS

The Z™-boom design provides lifting versatility with “up and over” positioning and excellent outreach. A tight turning radius and zero tailswing allow unmatched manoeuvrability in confined work areas.



PERFORMANCE AND TERRAINABILITY

Get the job done faster and more efficiently with a powerful combination of speed and gradeability. Genie’s full-time positive drive traction system and active oscillating axle work together based on ground conditions to help keep the machine moving without losing traction on rough terrain (oscillating axle not available on Z™-34/22 IC).



Genie® was the first in the industry to introduce the rotating jib.



POSITIONING AND CAPACITY

Powered rotation lets you move the platform exactly where you need it, while the self-leveling feature keeps the platform level through the entire range of motion. 227 kg (500 lbs) capacity is standard, easily handling up to two operators and tools. For enhanced platform positioning or to gain additional reach, choose models featuring a 1.22, 1.52, or 1.83 m (4, 5, or 6 ft) jib.

CHOICE AND VERSATILITY

Choose from four-wheel drive, engine, platform, axle and tyre options for the best configuration to meet your specific job site requirements. Need extra-rugged performance? Rough terrain models are excellent for traveling (stowed) over irregular or bumpy ground to a worksite.



ROUGH TERRAIN MODELS AVAILABLE

Z™-34/22 IC

Z™-45/25J RT

Z™-51/30J RT

Z™-60/34

ULTIMATE LIFTING VERSATILITY

The largest of the Genie® engine-powered articulating Z™-booms, these models have outstanding range of motion – with features like a telescoping jib and 360° continuous turntable rotation. Powerful engines, plus four-wheel drive and four-wheel steer take you to the work area efficiently, even over rough terrain. And the Z™-boom design provides excellent up and over positioning from 8.83 m (29 ft) on the Z™-80/60 to 23.01 m (75 ft 6 in) on the Z™-135/70.

EXCLUSIVE XCHASSIS™ AXLE DESIGN

The XChassis™ expanding axle revolutionizes the mechanism for extending and retracting the axles to and from the stowed position. It combines outstanding stability with the flexibility for easy transport at a stowed machine width of just 2.46 m (8 ft 1 in) on the Z™-135/70. The Z™-80/60 offers fixed-width axles for convenient transport.

ADVANCED CONTROLS

The ALC 1000 electronic control system provides menu-based adjustments for machine and component calibration as well as on-screen multi-language system diagnostics.



TRACTION FOR IRREGULAR TERRAIN

Four-wheel drive with full-time positive traction handles rough ground conditions to enhance the smoothness of the ride. The full time active oscillating axle on the Z™-80/60 maximises wheel contact on irregular terrain. Four-wheel steer comes standard on the Z™-135/70, with front wheel, rear wheel, crab and coordinated steer options available to provide additional manoeuvrability.

POWERFUL ENGINES

Quiet diesel engines like the turbocharged Deutz gives you more power and increased performance at higher altitudes, as well as plenty of torque for superior gradeability and terrainability.

The Genie® Jib-Extend™ telescoping jib extends from 3.66 to 6.10 m (12 to 20 ft)- providing outstanding reach and up-and-over clearance.

OUTSTANDING REACH AND UP-AND-OVER CLEARANCE

The Jib-Extend™ telescoping jib on the Z™-135/70 model extends from 3.66 to 6.10 m (12 to 20 ft) and provides a 110° vertical range of motion to reach “up, over and in” applications inaccessible by a traditional jib. The Z™-80/60 has an innovative reverse-articulating secondary boom for 8.83 m (29 ft) of up and over reach with zero front arm swing.

GENIE® FAST MAST™ SYSTEM

The Genie® Fast Mast™ system allows you to lower the platform to the ground without having to lower the secondary boom – so operators can ascend and descend quickly and efficiently. In addition, this timesaving design raises both primary and secondary booms simultaneously to help the operator reach full elevation fast and maximise productivity.

QUICK, FLEXIBLE POSITIONING

Both models have 360° continuous rotation turntables for fast, easy positioning. The platform also hydraulically rotates a full 160° and stays level throughout the entire range of motion. Choose 1.83 or 2.44 m (6 or 8 ft) front-entry platforms with 227 to 272 kg (500 to 600 lbs) of capacity for operators and tools.

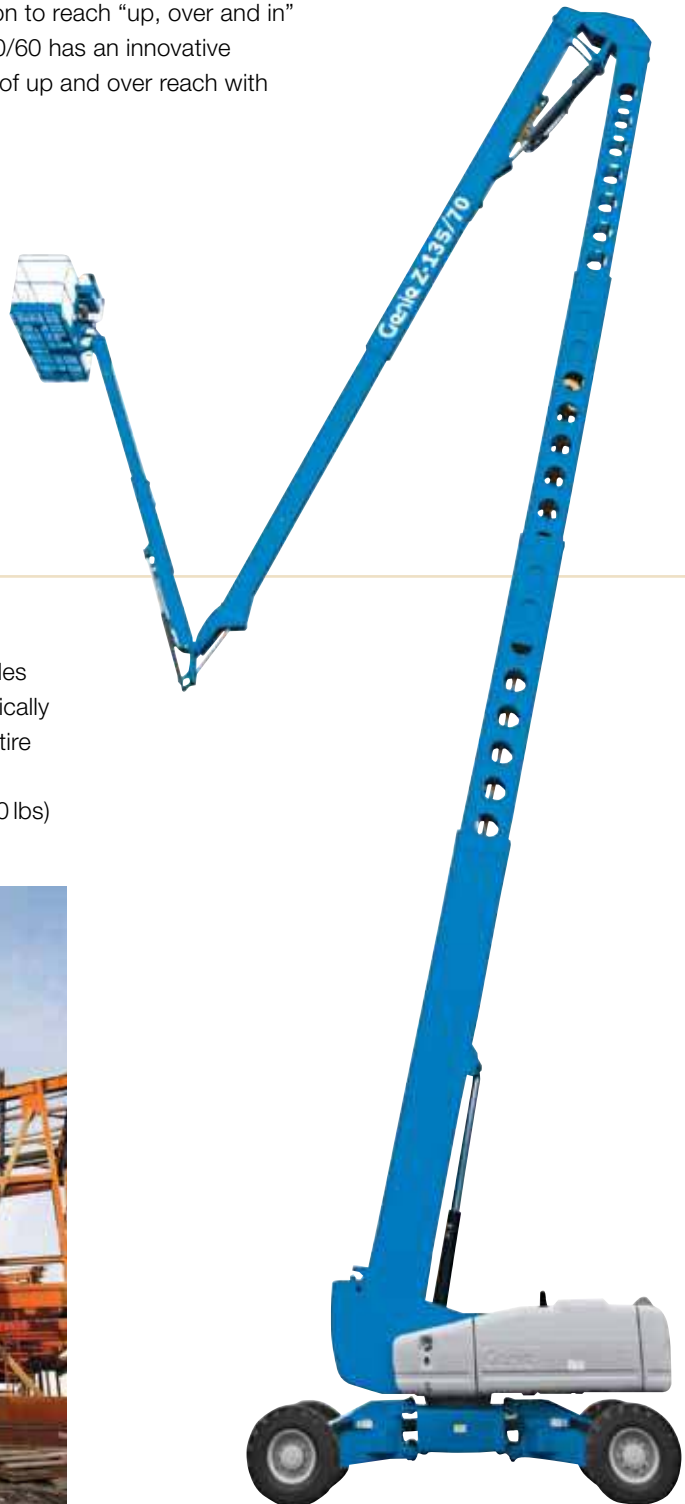

ROUGH TERRAIN MODELS AVAILABLE

Z™-80/60

Z™-135/70



OUTSTANDING HORIZONTAL OUTREACH

Telescopic booms offer greater horizontal outreach than any other type of aerial platform – perfect for areas with limited access in construction and industrial applications. Genie® telescopic S™-booms are also designed for productivity with the traction and drive speed you need to get around the job site and to the work area. These models reach out horizontally between 9.65 m (31 ft 8 in) and 23.30 m (76 ft 6 in), with working heights of 14.20 m (46 ft) to 27.90 m (91 ft).

GREAT FOR TIGHT SPACES

The 360° continuous rotation turntable rotates full circle for quick and flexible positioning. Minimal tailswing allows you to manoeuvre in tight work spaces. Plus, fixed width axles eliminate the need for additional set up by an operator after unloading from a transport trailer.



OUTSTANDING TERRAINABILITY

A revolutionary patented system automatically senses the terrain and adjusts the axle position based on ground conditions. Positive traction drive maintains equal power to all drive wheels, even if one wheel loses traction in mud, snow or sand. And four-wheel drive makes it easy to drive up loading ramps for transport.



Genie's revolutionary patented Full-time active oscillating axle system automatically senses the terrain and adjusts the axle position based on ground conditions.



SUPERIOR REACH AND POSITIONING

Exceptional horizontal outreach and a rotating, self-leveling platform allow precise positioning exactly where you need to work. For added flexibility, the articulating jib boom gives you an extra 1.52 m (5 ft) of horizontal or vertical reach and 135° of working range.



MAXIMISE PRODUCTIVITY YEAR-ROUND

Featuring a fixed, four-point track system, the S™-65 Trax models allow operators to manoeuvre in a diverse range of conditions. The rubber tracks provide increased flotation and traction for traveling in mud, sand, snow, gravel, in wet or rough terrain environments, and even on sensitive outdoor surfaces. Because the new Trax models are fixed with four independent tracks, they steer like a wheeled machine to allow manoeuvring close to walls and foundations. Plus, each track flexes 23° up and down for a smooth ride over undulating terrain and while loading on trailers.

ENGINE-POWERED MODELS AVAILABLE

S™-45

S™-65

S™-65 TRAX

S™-85

POWER AND TERRAINABILITY

Genie® Super Booms™ combine maximum reach with exceptional manoeuvrability. They feature rugged diesel engines, four-wheel drive and four-wheel steer capabilities, and foam-filled rough terrain tyres to quickly position you where you need to work. With horizontal outreach between 22.86 m (75 ft) and 24.38 m (80 ft) and working heights of 32.48 m (106 ft) to 40.15 m (131 ft 2 in), these machines set performance and operation standards for other booms on the market.



EXTRA WORKING RANGE

The out-and-up articulating jib boom gives you an additional 1.52 m (5 ft) of horizontal reach and height plus 135° of working range.

GREAT FOR TIGHT SPACES

The 360° continuous rotation turntable swings full circle for quick and flexible positioning. Minimal tailswing allows you to manoeuvre in tight workspaces.

DIESEL ENGINE OPTIONS

These models feature quiet diesel engines for more power and increased performance, even at high altitudes.



The horizontal outreach of the Genie® Super Boom™ line is among the industry's best at 22.86 to 24.38 m (75 to 80 ft), depending on the model.



PRECISE PLATFORM POSITIONING

Standard 2.44 m (8 ft) front-entry platforms can be rotated to exactly where you need to work and are self-leveling throughout the range of motion.



OUTSTANDING TERRAINABILITY

Model S™-125 comes standard with four-wheel drive and four-wheel steer to meet the demands of rugged outdoor use. It also features rough-terrain foam-filled tyres for maximum terrainability, traction and durability. Extendable axles allow you to extend or retract axles from the platform while driving for stability, ease of operation and convenient transport.



ENGINE-POWERED MODELS AVAILABLE

S™-125

CUSTOMISE YOUR BOOM

FOR SPECIFIC JOB SITE NEEDS



AUXILIARY TOP RAILING

PLATFORMS

Choose from 1.22, 1.52, 1.83 and 2.44 m (4, 5, 6 and 8 ft) steel platforms. Other options include a swing gate that replaces the standard sliding mid-rail for walk-in access to the platform.

PLATFORM ACCESSORIES INCLUDE:

Auxiliary Top Railing	Half-Height Mesh
Platform Control Box Cover	Platform Work Lights
Air Line to Platform	Tool Tray
Fluorescent Tube Caddy	

POWER

GENERATOR

7kVA hydraulic-driven generator options that supply power to the platform for operating tools without relying on an outside power source and extension cords.

POWER SYSTEM OPTIONS* INCLUDE:

Battery Charge Indicator	Hydraulic Oil Cooler
Second Battery	Low Voltage Interrupt with Battery Charge Indicator
Cold Weather Package	240 V power to platform



7 KVA HYDRAULIC GENERATOR

DRIVE, STEER AND TRACTION

Choose from two and four-wheel drive and two and four-wheel steer options (four-wheel steer not available on all models).

TYRE OPTIONS

Foam-filled: Rough terrain and industrial

Non-marking: Standard on solid rubber models (Z™-30, Z™-34 and Z™-40 families). Optional on most foam-filled models (except high flotation).



SOLID RUBBER TYRES

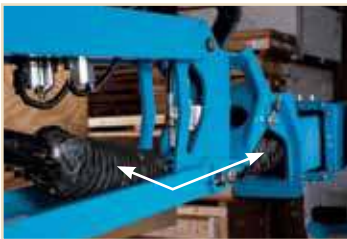

HOSTILE ENVIRONMENT PACKAGE

JOB SITE PROTECTION

HOSTILE ENVIRONMENT PACKAGE

The Basic kit includes cylinder bellows, boom wiper seals and a control box cover to protect the most critical boom and chassis areas from loose job site debris. The Deluxe kit adds a centre turntable shield, air intake pre-cleaner, cable track protection, and covers for vents and openings, for added protection from loose job site debris in applications such as sandblasting or painting.



AIRCRAFT PROTECTION SYSTEM

AIRCRAFT PROTECTION SYSTEM

The Standard kit includes a motion-shutoff, proximity-sensing mechanism under the platform to help protect sensitive surfaces from damage. The Deluxe kit adds high-visibility, dense foam padding on the railings for additional protection. Platform capacity is downgraded to 200 kg (440 lbs).

ENGINE

ENGINE OPTIONS

Diesel engines include Deutz and Kubota. (Engines depend on model.)

COLD WEATHER PACKAGE

Components vary depending on engine, but include synthetic engine oil. See sale representative for additional details.

ADDITIONAL OPTIONS

CHASSIS

Driving lights are available.

TOW PACKAGE

Allows the machine to be towed by another vehicle (the machine does not have use of its brakes when being towed and can only be towed at very low speeds). This package includes a tow bar, steering float valve and tow bar storage bracket.

SPECIFICATIONS

ARTICULATING Z™-BOOMS

MODEL	WORKING HEIGHT		WIDTH		HORIZONTAL REACH		UP & OVER CLEARANCE		LIFT CAPACITY	
	Metric	US	Metric	US	Metric	US	Metric	US	Metric	US
NARROW ARTICULATING Z™-BOOMS										
Z™-30/20N RJ	10.89 m	35 ft 2 in	1.19 m	3 ft 11 in	6.25 m	20 ft 6 in	3.86 m	12 ft 8 in	227 kg	500 lbs
Z™-34/22N	12.52 m	40 ft 6 in	1.47 m	4 ft 10 in	6.78 m	22 ft 3 in	4.62 m	15 ft 2 in	227 kg	500 lbs
Z™-40/23N RJ	14.32 m	46 ft 5 in	1.50 m	4 ft 11 in	6.91 m	22 ft 8 in	6.48 m	21 ft 3 in	227 kg	500 lbs
DC ARTICULATING Z™-BOOMS										
Z™-45/25J DC	15.92 m	51 ft 8 in	1.79 m	5 ft 10.3 in	7.65 m	25 ft 1 in	6.73 m	22 ft 1 in	227 kg	500 lbs
ENGINE-POWERED ARTICULATING Z™-BOOMS										
Z™-34/22 IC	12.62 m	40 ft 10 in	1.85 m	6 ft 1 in	6.78 m	22 ft 3 in	4.57 m	15 ft	227 kg	500 lbs
Z™-45/25J RT	16.07 m	52 ft 2 in	2.29 m	7 ft 6 in	7.65 m	25 ft 1 in	7.16 m	23 ft 6 in	227 kg	500 lbs
Z™-51/30J RT	17.62 m	57 ft 3 in	2.29 m	7 ft 6 in	9.25 m	30 ft 4 in	7.49 m	24 ft 6 in	227 kg	500 lbs
Z™-60/34	20.39 m	66 ft 4 in	2.46 m	8 ft 1 in	11.05 m	36 ft 3 in	8.23 m	27 ft	227 kg	500 lbs
Z™-80/60	25.77 m	84 ft	2.49 m	8 ft 2 in	18.29 m	60 ft	8.83 m	29 ft	227 kg	500 lbs
Z™-135/70	43.15 m	141 ft	2.46 m*	8 ft 1 in*	21.26 m	69 ft 9 in	23.01 m	75 ft 6 in	272 kg	600 lbs

*Axles retracted

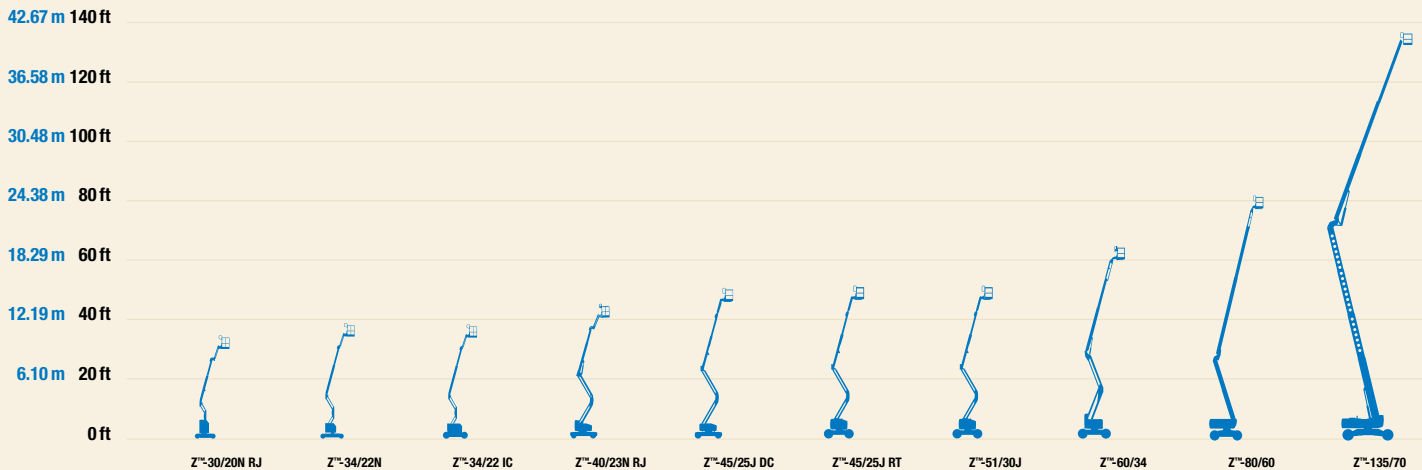

SPECIFICATIONS

TELESCOPIC S™-BOOMS

MODEL	WORKING HEIGHT		WIDTH		HORIZONTAL REACH		LIFT CAPACITY	
	Metric	US	Metric	US	Metric	US	Metric	US
STICK TELESCOPIC S™-BOOMS								
S™-45	15.72 m	51 ft	2.30 m	7 ft 6 in	11.18 m	36 ft 8 in	227 kg	500 lbs
S™-65	21.80 m	71 ft	2.49 m	8 ft 2 in	17.10 m	56 ft 2 in	227 kg	500 lbs
S™-65 TRAX	21.86 m	71 ft 2 in	2.59 m	8 ft 6 in	17.10 m	56 ft 2 in	227 kg	500 lbs
S™-85	27.70 m	91 ft	2.50 m	8 ft 2 in	23.30 m	76 ft 6 in	227 kg	500 lbs
SUPER TELESCOPIC S™-BOOMS								
S™-125	40.15 m	131 ft 2 in	2.49 m*	8 ft 2 in*	24.38 m	80 ft	227 kg	500 lbs

* Axles retracted

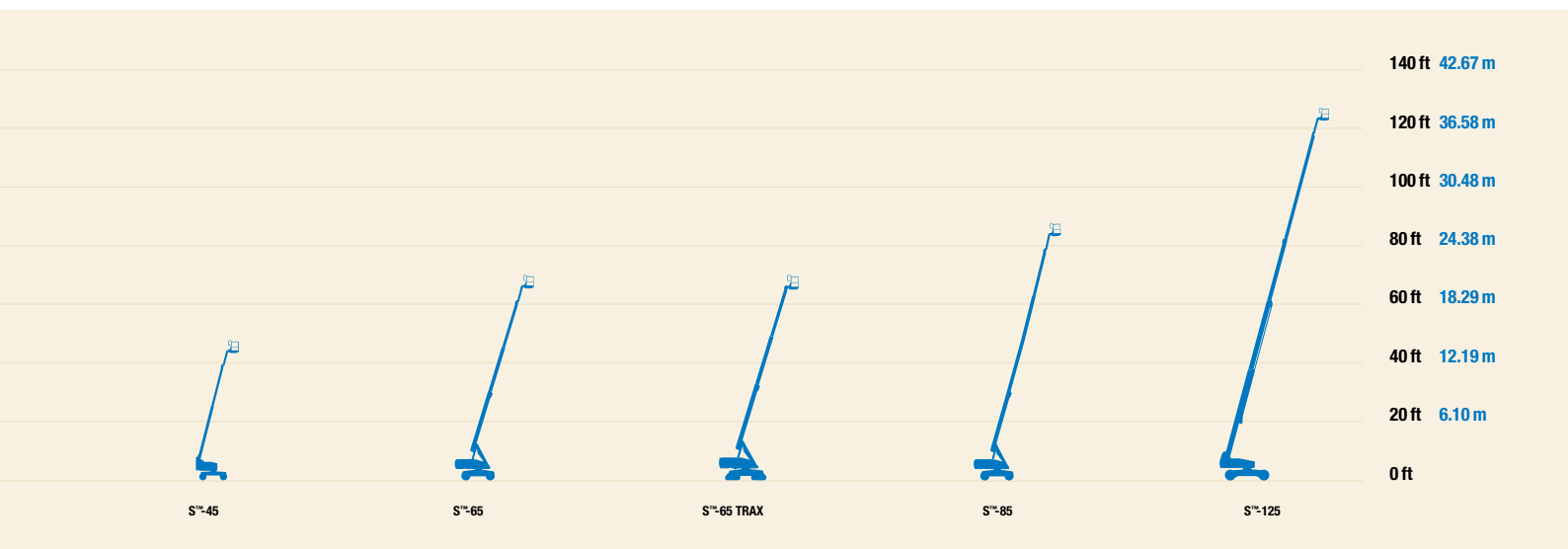



Genie®

A TEREX BRAND

www.genieindustries.com

Genie Australia – Toll free number 1800 788 633

Brisbane (Head Office)
33 Kimberley Street
Darra QLD 4076

Sydney
74 Glendenning Road
Glendenning NSW 2761

Melbourne
374 Hammond Road
Dandenong VIC 3175

Perth
126 Sheffield Road
Welshpool WA 6106

Genie United States

18340 NE 76th Street
P.O. Box 97030
Redmond, Washington
98073-9730

WORLDWIDE MANUFACTURING AND DISTRIBUTION

Australia • Brazil • Caribbean • Central America • China • France • Germany • Italy • Japan • Korea • Mexico
Southeast Asia • Spain • Sweden • United Arab Emirates • United Kingdom • United States

Effective Date: April 2012. Product specifications and prices are subject to change without notice or obligation. The photographs and/or drawings in this document are for illustrative purposes only. Refer to the appropriate Operators' Manual for instructions on the proper use of this equipment. Failure to follow the Operators Manual when using our equipment or to otherwise act irresponsibly may result in serious injury or death. The only warranty applicable to our equipment is the standard written warranty applicable to the particular product and sale and we make no other warranty, express or implied. Products and services listed may be trademarks, service marks, or trade names of Terex Corporation, Terex South Dakota, Inc., and/or their subsidiaries in the USA and other countries. All rights reserved. Terex is a registered trademark of Terex Corporation in the USA and many other countries. Genie is a registered trademark of Terex South Dakota, Inc. in the USA and many other countries. ©2009 Terex Corporation.