

Specifications

MODEL	SLC™-12		SLC™-18		SLC™-24	
Measurements	Metric	US	Metric	US	Metric	US
Working height:						
standard forks - forks down	3.40 m	11 ft 2 in	5.10 m	16 ft 9 in	6.78 m	22 ft 3 in
standard forks - forks up	3.94 m	12 ft 11 in	5.64 m	18 ft 6 in	7.32 m	24 ft
adjustable forks - forks down	3.40 m	11 ft 2 in	5.10 m	16 ft 9 in	6.78 m	22 ft 3 in
adjustable forks - forks up	3.94 m	12 ft 11 in	5.64 m	18 ft 6 in	7.32 m	24 ft
boom**	3.70 m	12 ft 2 in	5.41 m	17 ft 9 in	7.10 m	23 ft 3 in
A Height - stowed	2.18 m	7 ft 2 in	2.18 m	7 ft 2 in	2.18 m	7 ft 2 in
B Length - stowed	0.86 m	2 ft 10 in	0.86 m	2 ft 10 in	0.86 m	2 ft 10 in
C - operating	1.60 m	5 ft 3 in	1.85 m	6 ft 1 in	2.06 m	6 ft 9 in
A Width - stowed*	0.80 m	2 ft 7.5 in	0.80 m	2 ft 7.5 in	0.80 m	2 ft 7.5 in
- with stabilizers lowered	1.68 m	5 ft 6 in	1.68 m	5 ft 6 in	1.68 m	5 ft 6 in

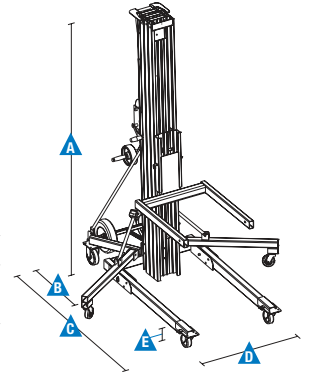

Productivity

Load capacity:						
14 in (36 cm) load centre	295 kg	650 lbs	295 kg	650 lbs	295 kg	650 lbs
24 in (61 cm) load centre	193 kg	425 lbs	193 kg	425 lbs	193 kg	425 lbs
42 in (107 cm) load centre	82 kg	180 lbs	73 kg	160 lbs	73 kg	160 lbs
A Ground clearance	0.05 m	2 in	0.05 m	2 in	0.05 m	2 in
Load height minimum	0.15 m	6 in	0.15 m	6 in	0.15 m	6 in

Power

Average cranks:						
standard winch	27.8 cranks/m	8.5 cranks/ft	27.8 cranks/m	8.5 cranks/ft	27.8 cranks/m	8.5 cranks/ft
two speed winch, high	13.1 cranks/m	4 cranks/ft	13.1 cranks/m	4 cranks/ft	13.1 cranks/m	4 cranks/ft
two speed winch, low	49.2 cranks/m	15 cranks/ft	49.2 cranks/m	15 cranks/ft	49.2 cranks/m	15 cranks/ft

Weight***

	102 kg	225 lbs	139 kg	307 lbs	157 kg	347 lbs
--	--------	---------	--------	---------	--------	---------

LOAD HANDLING ATTACHMENTS

Measurements	Metric	US	Weight - Metric	Weight - US
Standard forks (l/w/d)***	71 x 58 x 6 cm	28 x 23 x 2.5 in	12 kg	26.5 lbs
Adjustable forks (l/w/d)***	70 x 30-76 x 6 cm	27.5 x 12-30 x 2.5 in	24 kg	52.5 lbs
Fork extensions detached (each) (l/w/d)***	76 x 5 x 8 cm	30 x 2 x 3 in	2 kg	4.5 lbs
Fork extensions attached (each) (l/w/d)***	64 x 5 x 8 cm	25 x 2 x 3 in	2 kg	4.5 lbs
Boom (l/w/d)***	46-107 x 4 x 15 cm	18-42 x 1.5 x 6 in	18 kg	39.9 lbs
Pipe cradle (l/w/d)***/****	69 x 61 x 15.2 cm	27 x 24 x 6 in	4.5 kg	10 lbs
Load platform (l/w/d)***	67 x 58 x 6 cm	26.3 x 23 x 2.5 in	14 kg	31.5 lbs

* Outside dimensions.

** Measured from ground to bottom of shackle.

*** Length/Width/Depth.

**** Handles round objects up to 76 cm (30 in) in diameter.

Features

Standard Features

Measurements

SLC™-12

- 3.94 m (12 ft 11 in) maximum working height
- Up to 295 kg (650 lbs) lift capacity

SLC™-18

- 5.64 m (18 ft 6 in) maximum working height
- Up to 295 kg (650 lbs) lift capacity

SLC™-24

- 7.32 m (24 ft) maximum working height
- Up to 295 kg (650 lbs) lift capacity

Productivity

- Standard forks
- Heavy-duty design
- Strong, lightweight aluminum telescoping mast
- Single door access
- Quick set up requires no tools
- Interchangeable load handling attachments
- Non-marking 10 cm (4 in) front casters and 13 cm (5 in) rear casters with side brakes
- Rear transport wheel assembly
- Glide rails allow easy loading and unloading, on or off a vehicle, for transport
- Hold-down bar secures mast assembly during transport
- Captive stabiliser set (standard on SLC™-18, -24)
- Standard base

Power

- One speed manual winch

Options & Accessories

Productivity

- Boom
- Adjustable forks
- Fork extensions
- Pipe cradle
- Load platform
- Stabiliser set (option on SLC™-12)

Power Options

- Two speed manual winch



Genie – Toll free number 1800 788 633

Brisbane

HEAD OFFICE

33 Kimberley Street
Darra QLD 4076

Sydney

74 Glendenning Road
Glendenning NSW 2761

Melbourne

133 Logis Boulevard
Dandenong Sth VIC 3175

Adelaide

16-18 Nixon Road
Wingfield SA 5013

Perth

126 Sheffield Road
Welshpool WA 6106

Darwin

33 McCourt Road
Yarrowonga NT 0830

Genie USA

18340 NE 76th Street
P.O. Box 97030
Redmond, Washington
98073-9730

Distributed By:

Effective Date: July, 2015. Product specifications and prices are subject to change without notice or obligation. The photographs and/or drawings in this document are for illustrative purposes only. Refer to the appropriate Operator's Manual for instructions on the proper use of this equipment. Failure to follow the appropriate Operator's Manual when using our equipment or to otherwise act irresponsibly may result in serious injury or death. The only warranty applicable to our equipment is the standard written warranty applicable to the particular product and sale and we make no other warranty, express or implied. Products and services listed may be trademarks, service marks or trade names of Terex Corporation and/or their subsidiaries in the USA and many other countries. Genie is a registered trademark of Terex South Dakota, Inc. © 2018 Terex Corporation.